

5inch LED Down Light

Model : DL-0507-T108E

Application

This product is good for workshop, office, bank, hospital, shopping centre, subway, school, and other indoor places which require light of high luminosity and energy-saving.

Product Advantages:

1. Energy saving: It save more than 70% energy than traditional Down Light.
2. Eco-Green: No radiation, no mercury, no lead, no harmful elements, all products can be recycled
3. High light efficiency: The product can reach, 100lm/W
4. It is safe and easy to be used and installed



Model:DL-0507-T108E

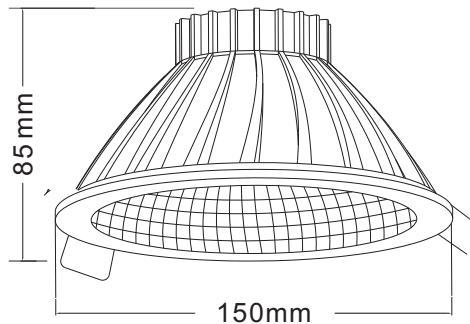

Standard

| | |
|-----------------------|--------------|
| Outer Diameter | Ø150mm |
| Hole Diameter | Ø125mm |
| Height | 85mm |
| Voltage (V) | AC85-265V |
| Beam Angle | 90 degree |
| Color Temp | 2700K~6500K |
| CRI | >80 |
| Luminous Efficacy | 100 lm/W |
| Luminous Flux(lm) | 700lm |
| Power Factor | > 0.92 |
| Power (W) | 7W |
| Material | AL 6063 |
| Life Span (Hrs) | up to 50,000 |
| Operating Temperature | -20°C~45°C |